

GARLOCK KLOZURE®

Split Klozure® Oil Seal

Installation Instructions

A split Klozure Oil Seal should be installed with the split at the top of horizontally mounted shafts.

To insure proper functionality and prevent damage of the split Klozure Oil Seal or equipment, following the installation instructions:

1. Insure the equipment meets the specification requirements for the split Klozure Oil Seal before continuing (shaft and bore diameter and surface finish and hardness).
2. Thoroughly clean and remove any burrs or sharp edges from the equipment.
3. Apply a thin coat of application lubricant to the shaft.
4. Open the split Klozure Oil Seal joint sideways (as shown in Figure 1) and place it around the shaft at a point near the recess into which the seal is to be installed.
5. Orient the split Klozure Oil Seal so the split is at the highest point (12 o'clock position).
6. Starting with the split ends, insert the seal into the housing bore. Care must be taken to ensure the split ends of the seal are touching. Compress the leading edge of the split Klozure Oil Seal (as shown in Figure 3) to install the seal into the housing.
7. Continue this process around the entire periphery of the shaft until the split Klozure Oil Seal is partially installed into the housing.
8. Seat the split Klozure Oil Seal in the housing by tapping the seal lightly with a mallet on a block of wood (or similar material (as shown in Figure 4)), using care to prevent damage to the seal or equipment. Once the seal is fully seated, approximately 0.015" will protrude from the housing, allowing compression of seal as described in Paragraph 7 (0.015" protrusion is not required for Model 26 split seals).
9. Bolt the cover plate tightly into position to compress the split Klozure Oil Seal into the housing, as shown in Figure 5 (refer to Figure 6 for cover plate recommendations).
10. When the split Klozure Oil Seal replaces the conventional seal, the equipment recess depth may be greater than the thickness of the split Klozure Oil Seal, thus requiring a filler. Filler gaskets or a split metal washer may be used for this purpose.
11. When a split Klozure Oil Seal is installed at the end of a plain or sleeve bearing, a drain or vent between the seal and the bearing is required to prevent pressure from building.

Figure 1



Figure 2



Figure 3

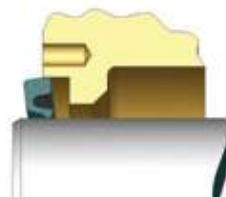

Figure 4

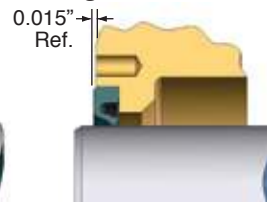

Figure 5



Note: Typical Model 23 figures shown for illustration purposes only.

GARLOCK KLOZURE®

Split Klozure Oil Seal

Installation Dimensions Figure 6

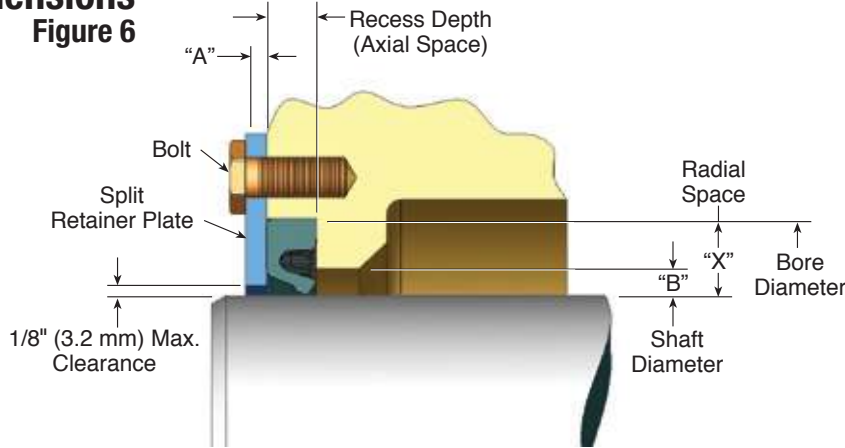

“B” = 0.28 “X” minimum,
0.5 “X” maximum

“X” = $\frac{\text{Bore Dia.} - \text{Shaft Dia.}}{2}$

* Figures shown are for guide only. Good machine design practices should be followed.

Shaft Diameter	No. of Bolts*	“A” Minimum Plate Thickness
3” to 8” (76.2 to 203.2 mm)	6	1/8” (3.2 mm)
Over 8” (Over 203.2 mm)	Bolt on max. of 6” (152.4 mm) chord, spacing centered on split in end plate	1/4” (6.4 mm)

AUTHORIZED DISTRIBUTOR

WARNING:

Properties/applications shown throughout this brochure are typical. Your specific application should not be undertaken without independent study and evaluation for suitability. For specific application recommendations consult Garlock. Failure to select the proper sealing products could result in property damage and/or serious personal injury.

Performance data published in this brochure has been developed from field testing, customer field reports and/or in-house testing.

While the utmost care has been used in compiling this brochure, we assume no responsibility for errors. Specifications subject to change without notice. This edition cancels all previous issues. Subject to change without notice.

GARLOCK is a registered trademark for packings, seals, gaskets, and other products of Garlock.

© Garlock Inc 2005. All rights reserved worldwide.

Garlock KLOZURE®

A Division of Garlock Sealing Technologies®

1666 Division Street

Palmyra, New York 14522 USA

1.315.597.4811

Fax 1.315.597.3140

Toll Free 1.866.KLOZURE (1.866.556.9873)

Toll Free Fax: 1.866.OILSEAL (1.866.645.7325)

Visit Klozure:

www.klozure.com

Other Garlock brand facilities are located in:

Columbia, SC, USA	1-803-783-1880	Fax: 1-803-783-4279
Houston, TX, USA	1-281-459-7200	Fax: 1-281-458-0502
Sydney, Australia	61-2-9793-2511	Fax: 61-2-9793-2544
São Paulo, Brazil	55-11-4352-6161	Fax: 55-11-4352-8181
Sherbrooke, Canada	1-819-563-8080	Fax: 1-819-563-5620
West Yorkshire, England	44-1422-313600	Fax: 44-1422-313601
Saint-Étienne, France	33-4-7743-5100	Fax: 33-4-7743-5151
Neuss, Germany	49-2131-3490	Fax: 49-2131-349-222
Mexico City, Mexico	52-555-567-7011	Fax: 52-555-368-0418
Shanghai, China	86-021-62789702	Fax: 86-021-62787826
Singapore	65-6285-9322	Fax: 65-6284-5843
Dubai, UAE	971-4-8833652	Fax: 971-4-8833682

PRINTED IN U.S.A.

KLZ 2:43

VIA-7/04 Rev A

Bring KLOZURE® to all your sealing requirements



Garlock Sealing Technologies® is an EnPro Industries company.

